



GEO-CENTERS

January 6, 2002

Air Cycle Corporation
2000 S. 25th Avenue, Suite C
Broadview, IL 60155

Attention: Scott Beirwaltes

Subject: The Bulb Eater™ Model 55 VRS Mercury Emissions' Sampling and Evaluation Report

Dear Mr. Beirwaltes:

GEO-CENTERS, INC. is pleased to provide The Bulb Eater™ Model 55 VRS Mercury Emissions' Sampling and Evaluation Report. The Bulb Eater evaluation was performed in accordance with GEO-CENTERS, INC. proposal number GC-P-02-3517.

The primary purpose of the evaluation was to evaluate mechanical integrity improvements made to the Bulb Eater™ Model 55 VRS by the evaluation of the system's mercury vapor emissions. The mechanical integrity improvements were made to eliminate or minimize mercury vapor emissions from the fluorescent lamp crushing device. This report contains the details of The Bulb Eater™ Model 55 VRS air sampling and industrial hygiene evaluation associated with crushing 1500 spent fluorescent lamps. The evaluation was performed 22-25 October 2002 at the Air Cycle Corporation headquarter facilities located at 2000 S. 25th Avenue, Suite C, Broadview, IL. The evaluation was performed by GEO-CENTERS, INC. Certified Industrial Hygienist, Mr. J. Brice Chastain, Jr. (C.I.H. #4850, certified by the American Board of Industrial Hygiene).

Please contact Mr. Brice Chastain, C.I.H., at 843-881-0506 or 843-442-2178 or by email (bchastain@geo-centers.com) if you have questions or comments regarding its contents.

Sincerely,

Brice Chastain, C.I.H.
GEO-CENTERS, INC.
Engineering Technology Operation
2451 Crystal Park V, Suite 802
Arlington, VA 22202



GEO-CENTERS

**The Bulb Eater™ Model 55 VRS
Mercury Emissions' Sampling and Evaluation Report**

For

Air Cycle Corporation
2000 S. 25th Avenue, Suite C
Broadview, IL 60155

Performed by:

J. Brice Chastain, Jr. C.I.H.
GEO-CENTERS, INC.
Engineering Technology Operation
1201 M. Street S.E., Suite 050
Washington, DC 20003

06 January 2003



GEO-CENTERS

Bulb Eater™ Model 55 VRS (Navy Prototype)

Mercury Emissions' Sampling and Evaluation Report

Introduction:

GEO-CENTERS, INC. performed an industrial hygiene evaluation of Air Cycle Corporation's Bulb Eater™ Model 55 VRS to evaluate mechanical integrity improvements made to eliminate or minimize mercury vapor emissions generated during fluorescent lamp crushing. Excessive exposure to various forms of mercury via inhalation has been shown to adversely affect the human central nervous system, lungs, kidneys, skin, and reproductive system. Air Cycle Corporation is proactively pursuing mechanical integrity solutions to eliminate and minimize mercury vapor leakages and thereby reduce health and environmental risks associated with the system's operation.

The test and evaluation was performed by GEO-CENTERS, INC. Certified Industrial Hygienist October 22-25, 2002 at Air Cycle Corporation's facilities located at 2000 S. 25th Avenue, Suite C, Broadview, IL. The test and evaluation involved smoke tube leakage tests and operator, perimeter area, and emissions' control device area air sampling during two test cycles involving crushing of 1500 – 1600 fluorescent lamps. Noise levels generated from the crushing operation were also evaluated.

Purpose of Tests

The Bulb Eater™ system tests were designed to quantify airborne concentrations of mercury vapor and liquid mercury particulate emissions at various locations around the unit to evaluate recent mechanical integrity improvements, compare the exposure potential of the operator and surrounding operating environment to OSHA standards and ACGIH Threshold Limit Values for mercury, and assess noise levels generated.

Mercury Standards

Occupational Safety and Health Standards

The Occupational Safety and Health Administration (OSHA) regulation Title 29 of the Code of Federal Regulations (CFR) 1910.1000, Air Contaminants, Table Z-2, and an OSHA Compliance Directive Interpretation of 9 September 1996 regarding mercury exposure limits has set the Permissible Exposure (PEL) for all forms of mercury at 0.10 milligrams per cubic meter (mg/m^3) of air (equivalent to 6.1 parts per billion, ppb). The Permissible Exposure Limit (PEL) is an eight-hour Time Weighted Average (TWA) concentration limit in air that nearly all workers can be exposed to without adverse health effects. The American Conference of Governmental Industrial Hygienists (ACGIH) Threshold Limit Values for Chemical Substances and Physical Agents for 2002 has set recommended air standards for the elemental and inorganic forms of mercury (including inorganic mercury vapor) at 0.025 milligrams per cubic meter (mg/m^3) as an eight-hour Threshold Limit Value (TLV) Time Weighted Average (TWA) concentration in air. A "Skin" notation is also designated with the standard indicating skin, eye and mucous membrane contact as a significant pathway of absorption.

When both OSHA and ACGIH provide applicable standards to a given situation, i.e., occupational exposure limits to mercury, the most prudent approach is to use the more stringent of the two standards. Therefore the ACGIH TLV-TWA for mercury of 0.025 mg/m³ is applicable. Table 1 provides a summary of mercury vapor exposure limits by various organizations including OSHA, ACGIH, the National Institute of Occupational Safety and Health (NIOSH) and the National Academy of Sciences (NAS).

Table 1. Mercury Vapor Exposure Limits Summary							
OSHA PEL 8-Hour TWA (mg/m³)	ACGIH TLV 8-Hour TWA (mg/m³)	ACGIH 30-minute Excursion Limit (mg/m³)	ACGIH Instantaneous Excursion Limit (mg/m³)	NIOSH REEL- TWA (mg/m³)	NIOSH IDLH (mg/m³)	NAS SMAC 1-Hour TWA (mg/m³)	NAS SMAC 24-Hour TWA (mg/m³)
0.1 (Skin) [12.2 ppb]	0.025 (Skin) [3.0 ppb]	0.075 (Skin) [9.1 ppb]	0.125 (Skin) [15.2 ppb]	0.05 (Skin) [6.1 ppb]	10.0 [1,219 ppb]	0.08 [9.8 ppb]	0.02 [2.4 ppb]

Table Abbreviations and Notes

- ACGIH American Conference of Governmental Industrial Hygienists - 2002 Threshold Limit Values
- IDLH Immediately Dangerous To Life And Health
- mg/m³ Milligrams Per Cubic Meter (air)
- NAS National Academy of Sciences
- NIOSH National Institute of Occupational Safety and Health
- PEL Permissible Exposure Limit
- ppb Parts per billion (in air)
- OSHA Occupational Safety and Health Administration
- REEL Recommended Environmental Exposure Limit
- Skin Percutaneous (dermal) exposure (as route of exposure)
- SMAC Spacecraft Maximum Allowable Concentrations for Selected Airborne Contaminants (1996)
- TLV Threshold Limit Value
- TWA Time Weighted Average

The Bulb Eater™ Model 55 VRS

Air Cycle Corporation¹ manufactures the Bulb Eater™ line of fluorescent lamp crushing devices. The Bulb Eater™ unit mounts on top of a 55-gallon or 30-gallon drum (half the height of the 55-gallon drum) as shown in Figure 1. The spent fluorescent lamp is fed through a 45° entry tube connected to the Bulb Eater™ lamp entry tube. An electric motor spins a chain inside the unit breaking each inserted lamp. Entry tubes are available in 2-foot, 4-foot, and 8-foot lengths. Each entry tube connects to the top of the unit by a threaded connection. The system also includes inserts for specific tube lengths, shapes, and diameters to ensure that the fluorescent lamp tube does not break outside of the feed tube. A vacuum pump vents the mercury vapor through the unit's three-stage filtration system. The first two stages consist of a filter bag followed by a HEPA filter to remove particulates. The bag and HEPA filter are contained together in a single housing unit termed "HEPA filter housing" for the purposes of this report.

¹ Air Cycle, Corp., Broadview, IL, www.aircycle.com

The filter bag must be replaced after filling each 55-gallon crushed lamp waste drum, while the HEPA filter must be replaced every 10 drums. The HEPA filter housing is attached to the final stage filter, a 22-lb activated carbon canister. Air Cycle Corporation reports the carbon canister filter has an estimated life of one million lamps.

The Bulb Eater™ system will crush approximately 750 to 800 4-foot spent fluorescent lamps into a 55-gallon drum and the unit is capable of processing 24 lamps per minute. The total system cost is \$3,506.00 and includes a 10” storage drum for attaching the unit when not in use.

Air Cycle Corporation made many mechanical integrity improvements during the latter half of 2002 to eliminate mercury emissions at potential leakage points (e.g. connections, fittings, attachments, etc.) as a result of mercury emission concerns by the U.S. Navy. Also newly developed for the system is the addition of a 10” storage drum for attaching the unit when not in use. The storage drum prevents phosphor and mercury particulate residue on the chain side of the unit from contaminating the storage area when not in use and when not mounted atop a 55-gallon waste drum. The 10” storage drum also saves space when the unit is stored. Air Cycle Corporation also improved the system further by including an air purge cycle that will run the vacuum pump for 7 to 10 seconds after the machine is turned off, a drum open sensor that cuts off the motor if the drum lid is opened, and a new control panel complete with indicator lights. The result of these efforts is the Bulb Eater™ Model VRS system. Figure 1 displays the Bulb Eater™ Model VRS system atop a 55-gallon crushed lamp waste drum.



Figure 1. The Bulb Eater™ Model 55-VRS

Test Plan and Sampling Strategy

Test Schedule

The Bulb Eater Eater™ system tests and evaluation was planned and scheduled for October 22-25, 2002 at Air Cycle Corporation warehouse facilities in Broadview, IL.

Lamp Test Inventory Selection

Air Cycle Corporation carefully staged 1,617 spent 4-ft. T-10 and T-12 lamps in Air Cycle Corporation's warehouse bay area prior to the tests. Each 4-ft lamp contains on average a concentration of mercury ranging from 12 to 20 milligrams. Table 3 contains a breakout of the type and number of lamps crushed.

Table 3. Test Lamp Inventory		
Lamp Types	Approximate Number of Lamps Collected	Percentage of Total
4-ft. T-10	238	15 %
4-ft. T-12	1379	85 %
Total	1617	100 %

Test Site Preparation

The Bulb Eater™ test site, Air Cycle Corporation's headquarter facility warehouse bay area was heated and equipped with an operating general dilution ventilation system during the test period. Prior to conducting the tests a protective 10-ft. x 10-ft. polyethylene tarp (5-millimeter (mil) thickness) was secured to the floor. Each crushed lamp waste collection drum was centered on the protective floor tarp prior to initiating each test. The tarp served as a barrier between the crushed lamp waste collection drum and the floor in the event of accidental crushed lamp waste spillage and also eased clean up after the tests.

The Bulb Eater™ unit was assembled atop a 55-gallon waste drum in the test area by the operator and helper prior to testing in accordance with Air Cycle Corporation Bulb Eater™ owner's manual instructions. All fittings, clamps, and fasteners were put in place and checked to ensure proper attachment, tightness, seals, etc. prior to each test cycle.

Safety Precautions

The Bulb Eater™ operator, helper and CIH wore personal protective equipment (PPE). The PPE worn included neoprene-coated, chemical-, abrasion-, and cut-resistant gloves, disposable Tyvek® coveralls with attached boot covers, chemical safety goggles, and steel-toed safety boots and earplugs.

At the completion of the two cycle tests, gloves, disposable coveralls with boot covers were removed prior to exiting the test area. Prior to PPE removal, the PPE, clothing worn

underneath PPE, and exposed skin areas were spot checked for mercury contamination using the Jerome Mercury Vapor Analyzer. The disposable coveralls and gloves were stored in sealed and plastic bags and held for disposal with other mercury-contaminated expendables in accordance with local hazardous waste requirements and procedures.

Plastic floor tarps were periodically checked using the Jerome 431 Mercury Vapor Analyzer for mercury contamination during the test operations and prior to clean up after each test.

After the tests were completed on 24 October 2002, the protective floor tarp plastic containment was disposed as mercury contaminated waste.

The test personnel washed their arms, face, and hands after the two test cycles were completed.

Smoke Tube Tests

A Draeger smoke tube kit containing an aspirator bulb and smoke tubes were used to assess air leakage points around the unit at mechanical connections, attachments, openings, seams, etc., prior to the performance of air sampling tests. The smoke tube tests provided a visual indication of potential locations where excessive mercury vapor emissions can be expected. The smoke test was also conducted after the two cycle tests were completed in order for Air Cycle Corporation technical and manufacturing staff to recognize the system's leakage points as indicated by smoke movement.

Mercury Emissions' Sample Locations

A factory calibrated gold film mercury vapor analyzer, a Jerome 431 Mercury Vapor Analyzer direct reading instrument (DRI), was used to collect real-time mercury concentrations in the ambient air before, after, and during each test cycle at all mechanical connections, junctures, and openings where mercury vapor could be emitted. The DRI was also used to spot check mercury vapor concentrations in the operator's breathing zone and to check for mercury surface contamination on the unit and waste drum, and to measure breathing zone mercury vapor concentrations during waste drum change-out operations. DRI measurements were also made at locations indicated by the results of the smoke tube tests.

The Jerome 431 Mercury Vapor Analyzer is manufactured by the Arizona Instruments Corporation, Tempe, Arizona, has a range of 0.000 to 1.999 mg/m³ mercury, an accuracy of (+/- 5%), a mercury vapor sensitivity of 0.003 mg/m³, and a measurement resolution of 0.001 mg/m³. The instruments' response time is ten seconds in the sample mode and one second in the survey mode. The instrument's microprocessor automatically re-zeroes the digital meter at the start of each sample cycle and freezes the meter reading until the next sample cycle is activated, thus eliminating drift between samples. The Jerome 431 direct reading instrument was operated in the sample mode during the tests.

The Bulb EaterTM direct reading instrument primary sample locations are presented in Figure 2. Other areas on the unit were sampled as a result of smoke tube tests.

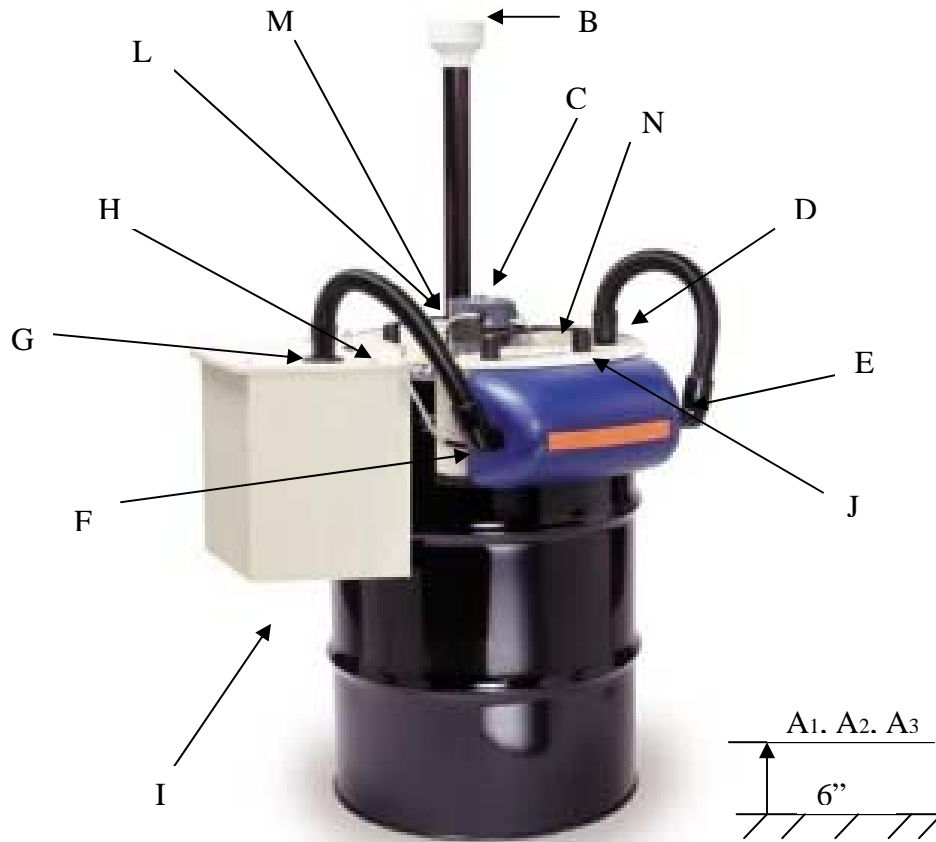

Figure 2. The Bulb Eater™ Model 55 VRS (Navy Prototype) Sample Points	
Sample Point	Description
A ₁	Ambient Hg concentration before test cycle, 4-6 inches above floor
A ₂	Ambient Hg concentration after test cycle, motor on, 4-6 inches above floor
A ₃	Ambient Hg concentration after A2 sample collected, motor off, 4-6 inches above floor
B	Fluorescent lamp chute entry point
C	Motor housing area
D	HEPA filter air hose connection exit from drum top lid
E	HEPA filter air hose connection entry to HEPA filter housing
F	HEPA filter air hose connection exit from HEPA filter to carbon filter
G	HEPA air hose connection entry to carbon filter
H	Carbon filter housing lid rim area
I	Fan exit air stream
J	Drum lid rim near HEPA filter
K	Drum lid rim area near carbon filter
L	Fluorescent lamp chute entry connection to drum top
M	Drum lid rim area opposite HEPA filter
N	Drum lid rim area opposite carbon
OBZ	Operator breathing zone (not shown in Figure 5.)

Figure 2. The Bulb Eater™ Model 55 VRS (Navy Prototype) Sample Points	
Sample Point	Description
Other	Other areas as indicated by smoke tube testing (e.g. HEPA filter housing seams)



Personal and Area Air Sampling for Mercury Vapor

Five calibrated low flow air sampling pumps attached to SKC Inc. Anasorb CSC[®] charcoal tubes designed for mercury vapor collection protected in tube holders by Tygon[®] tubing were used by the project Certified Industrial Hygienist (CIH) to collect personal and area air samples for mercury vapor. The Anasorb CSC[®] charcoal tubes have a quantitative limit of detection of 0.02 micrograms (μg) mercury. The SKC low flow air pumps were calibrated at 180- 210 milliliters per minute (ml/min). A SKC DryCal DC-Lite Flowmeter (2-500 ml/min) was used to calibrate the eight SKC Aircheck low flow pumps before and after the tests.

Time-weighted average (TWA) air samples were collected in the Bulb Eater[™] operator breathing zone on the North side of the Bulb Eater[™] and three area air samples were collected within 5-6 ft of the unit on the East, West, and South sides during each test cycle. One area air sample was collected within six inches of and adjacent to The Bulb Eater[™] mercury vapor emission control device exhaust during each test cycle. One field sample blanks, one media blank, and one spike matrix blank were also collected during the two test cycles.

Personal and area air sample results were compared to OSHA standards and the ACGIH recommended standards for mercury vapor presented in Table 1.

Laboratory Analyses of Personal and Area Air Samples

Martel Laboratories JDS, Inc., 1025 Cromwell Bridge Road, Baltimore, MD performed air sample analyses for mercury vapor content following NIOSH Method 6109, Mercury Analysis, for the personal and area air samples collected.

Qualitative Sampling for Presence of Mercury Surface Contamination

A mercury surface sampling kit was available and used to qualitatively detect the presence of mercury on the surfaces of the waste drums at the completion of the each test cycle. The purpose of the qualitative tests was to detect the presence of mercury particulate contamination possibly present on the drums resulting from drum change-out operations.

Noise Survey

A calibrated Quest 2100 Sound Level Meter (SLM) was used by the CIH to assess noise levels (in dBA) generated by the Bulb Eater[™] during crushing operations.

Instrument Calibration

Each instrument used during the tests was calibrated daily before and after each use or as required following manufacturers' recommended calibration procedures and using required calibration equipment. Records of instrument calibrations were available on-site during the tests and are provided in Appendix A.

Tools and Equipment

Other equipment such as hand tools was also used during the setup and instrumentation for each test.

Appendix A, Table A-1 provides a complete list of tools and equipment assembled and used during the Bulb Eater™ test and evaluation.

Test Results

Mercury Vapor Sampling Summary

A summary containing sample types and total number of samples collected during the each Bulb Eater™ test cycle is provided in Table 4.

Table 4. Bulb Eater™ Model 55VRS (Navy Prototype) Air Sampling Summary	
Sample Type	Samples Collected
Air - Personal TWA	2
Air - Area TWA	6
Air – Exhaust Air Area TWA	2
Air - Field Blanks	1
Air – Media Blanks	1
Air – Matrix Spike Blank	1
DRI – Jerome 431	255
Totals	268

Personal and Area Mercury Vapor Sample Results and Analysis

During each test cycle, personal and area air samples were collected to assess both the actual and potential occupational exposure to the operator and helper to mercury vapor generated during crushing fluorescent lamps. Eight-hour time-weighted average (TWA) samples collected in the operator’s breathing zone and area air sample results were compared to the OSHA and ACGIH mercury vapor standards presented in Table 1.

During the two test cycles, 2 personal time-weighted average (TWA) breathing zone samples were collected on Anasorb charcoal tubes connected by Tygon® tubing to low flow air pumps in the lapel area (i.e., breathing zone) of the Tyvek® suits worn by the operator. The calibrated air pump was placed inside the operator’s Tyvek® suits on his belt.

A total of 6 area air samples were collected on charcoal tubes at three points around the Bulb Eater™ during each test. These included area air samples collected at a distance of 5 to 6 feet on the East, South, and West sides of the Bulb Eater™ and at a height of 5 feet

approximating breathing zone height. The operator was located on the north side equipped with a personal sample sampling train. As a result no area air sample was collected on the North side of the unit during each test. Additionally, one area sample was collected during each test cycles within 6 inches of the Bulb Eater™ air discharge point ~ 2inches under the system's emission control device (i.e., carbon filter) and 5 inches from the floor during each test cycle.

Personal and area air samples collected including field, media and matrix spike blanks for the charcoal tube sample media were submitted to Martel Laboratories JDS, Inc. of Baltimore, MD on 28 October 2002 following the Bulb Eater™ tests. The CIH completed chain of custody forms provided by Martel and requested laboratory analysis for mercury. Martel analyzed the charcoal tube samples for mercury content. The samples were analyzed for mercury by cold vapor atomic absorption following the National Institute of Occupational Safety and Health (NIOSH) Method 6009 for elemental mercury analysis. Analytical results were reported in milligrams (mg). Martel Laboratories JDS, Inc. reported the minimum detection limit for the analytical method for the samples analyzed as 0.00005 mg/m³. Laboratory analytical results for personal and area samples collected and sample chain of custody forms are contained in Appendix B.

The analytical results received from the laboratory on 11 November 2002 were used to calculate each sample mercury concentration in milligrams per cubic meter (mg/m³).

The TWA and 8-hour TWA sample results for each sample were used during each test cycle to evaluate actual exposure to the operator and potential for exposure to the surrounding area within five feet of the Bulb Eater™ crushing operation and at the air discharge area of the Bulb Eater™ emission control device.

Field notes of all samples collected and analyzed including sample type, sample locations, instrument calibrations, and observations were recorded and maintained in the CIH's field notes.

The test data contained in Tables 5, 6, and 7 are presented by "Test Date", "Exposure Duration", "Number of Lamps Crushed", "TWA During Operation" and "8-Hour TWA". TWA sample results are reported in mg/m³. TWA and 8-Hour TWA sample result values reported as "ND" (Not Detected) were determined to be less than the analytical detection limit of 0.00005 mg, the analytical method for mercury, and TWA calculations were not performed and are reported as "Not Detected".

Table 5 contains a summary of operator mercury vapor TWA exposure results for each Bulb Eater™ test cycle.

Table 5. Mercury Vapor Exposure⁽¹⁾ Summary For The Bulb Eater™ Operator⁽²⁾ During Crushing Operations				
Date	Exposure Duration (min.)	Number Lamps Crushed	TWA During Operation (mg/m³)	8-Hour TWA (mg/m³)
24Oct02	83	750	ND	ND
24Oct02	82	750	ND	ND

Table Notes:

- (1) Mercury analytical detection limit 0.00005mg; therefore TWA and 8-Hour TWA sample result values reported as “ND” (Not Detected) were determined to be less than the analytical detection limit of the analytical method for mercury and TWA calculations were not performed.
- (2) All samples were collected in the operator’s breathing zone.

Table 6 contains a summary of East, West, and South perimeter area sample mercury vapor TWA exposure results for each test cycle.

Table 6. Mercury Vapor Exposure⁽¹⁾ Summary For Bulb Eater™ Test Area Samples					
Date	Location⁽²⁾	Exposure Duration (min.)	Number Lamps Crushed	TWA During Operation (mg/m³)	8-Hour TWA (mg/m³)
24Oct02 (1 st Test Cycle)	East Side	82	750	ND	ND
24Oct02 (1 st Test Cycle)	South Side	82		ND	ND
24Oct02 (1 st Test Cycle)	West Side	83		ND	ND
24Oct02 (2 nd Test Cycle)	East Side	82	750	ND	ND
24Oct02 (2 nd Test Cycle)	South Side	82		ND	ND
24Oct02 (2 nd Test Cycle)	West Side	82		ND	ND

Table Notes:

- (1) Mercury analytical detection limit 0.00005mg; therefore TWA and 8-Hour TWA sample result values reported as “ND” (Not Detected) were determined to be less than the analytical detection limit of the analytical method for mercury and TWA calculations were not performed.
- (2) Each area sample collected at 5 feet height approximating breathing zone level

TWA area sample results and for area samples collected within 2 inches of the Bulb Eater™’s emission control device 5 inches above the floor in the air exhaust stream is presented in Table 12.

Table 7. Mercury Vapor Exposure⁽¹⁾ Summary For Bulb Eater™ Emissions’ Control System Air Exhaust Stream⁽²⁾ During Crushing Operations				
Date (Sample Type)	Exposure Duration (min.)	Number Lamps Crushed	TWA During Operation (mg/m³)	8-Hour TWA (mg/m³)
24Oct02 (1 st Test Cycle)	70	750	ND	ND
24Oct02 (1 st Test Cycle)	82	750	ND	ND

Table 12 Notes:

(1) Mercury analytical detection limit 0.00005 mg; therefore TWA and 8-Hour TW82A sample result values reported as “ND” (Not Detected) were determined to be less than the analytical detection limit of the analytical method for mercury and TWA calculations were not performed.

(2) Samples collected in the operator’s helper’s breathing zone.

TWA and 8-hour TWA sample results contained in Tables 5 for the operator did not exceed the 0.025mg/m³ ACGIH TLV-TWA air contaminant standard for mercury vapor or the 0.1 mg/m³ OSHA PEL-TWA air contaminant standard for mercury vapor during the two Bulb Eater™ test cycles or over the 8-hour work day that the two test cycles were performed.

Similarly, the 6 area samples collected at breathing zone level within five feet on three sides of the Bulb Eater™ and within six inches from the unit’s emissions’ control device’s exhaust air stream exit point did not exceed the 0.025mg/m³ ACGIH TLV-TWA air contaminant standard for mercury vapor or the 0.1 mg/m³ OSHA PEL-TWA air contaminant standard for mercury vapor during the two test cycles or over the 8-hour work day that the two test cycle was performed.

Based on air contaminant sampling results, the operator and surrounding areas are not exposed to excessive concentrations of mercury vapor associated with the Bulb Eater™ operation. Additionally, the Bulb Eater™ emission control device exhaust air streams were not laden with detectable mercury vapor airborne concentrations.

Direct Reading Instrument Measurements

Approximately 255 DRI measurements were made with the Jerome 431 Mercury Vapor Analyzer during the Bulb Eater™ tests. These measurements were made to assess mercury vapor leakage points, to obtain real-time (10-second integrated) mercury vapor test personnel exposure data, to monitor the surrounding test area, and for performing assessments of mercury vapor surface contamination on the test personnel skin, clothing, and PPE, and the Bulb Eater™ unit during and after tests, waste collection drums, test area containments, and test equipment.

The Bulb Eater™ Model 55VRS (Navy Prototype) DRI Measurement Summary

A summary of the Jerome Mercury Vapor Analyzer DRI sample results for the Bulb Eater™ Model 55VRS (Navy Prototype) tests are presented below in Tables 8, 9, and 10. The sample measurements highlighted in yellow reveal locations on the Bulb Eater™ where mercury vapor concentrations equaled or exceeded the ACGIH TLV-TWA equal to 0.025 mg/m³. The sample measurements highlighted in the color green reveal locations on the Bulb Eater™ where mercury vapor concentrations equaled or exceeded the OSHA PEL-TWA equal to 0.100 mg/m³. DRI measurements were made within two to three inches of the Bulb Eater™ unit at each of the sample points and within six inches directly beneath the air exhaust area of the Bulb Eater™,s emissions' control device.

Table 9. Bulb Eater™ Model 55 VRS (Navy Prototype) DRI Measurements Summary
Background Readings at Test Location
24 October 2002

Sample Point	Description	1 st Reading (mg/m3)	2 nd Reading (mg.m3)	3 rd Reading (mg.m3)	Avg. Value mg/m3	Time Hr:Min	Lamp Count
O ₁	Other – Background (OBZ) at test location prior to start-up	0.000	0.000	0.000	0.000	10:10	0
O ₂	Other – Background (OBZ) at test location prior to start-up	0.000	0.000	0.000	0.000	10:12	0
O ₃	Other – Background; 6 inches above floor directly under Bulb Eater exhaust	0.000	0.000	0.000	0.000	10:13	0
O ₄	Other – Background; OBZ position	0.000	0.000	0.000	0.000	10:20	0

Table 9. Bulb Eater™ Model 55 VRS (Navy Prototype) DRI Measurements Summary
First Test Cycle
24 October 2002

Sample Point	Description	1 st Reading (mg/m3)	2 nd Reading (mg.m3)	3 rd Reading (mg.m3)	Avg. Value mg/m3	Time Hr:Min	Lamp Count
A ₁	Ambient Hg conc. before motor on, 4-6" above floor	0.000	0.000	0.000	0.000	10:25	0
O ₁	Other – Background; OBZ position prior to start-up	0.000	0.000	0.000	0.000	10:27	0
O ₂	Other – Background; 6 inches above sampling equipment table	0.000	0.000	0.000	0.000	10:29	0
A ₂	Ambient Hg conc. after, motor on, 4-6" above floor	0.000	0.000	0.000	0.000	13:15	0
B	Lamp chute entry point						
L	Lamp chute entry connection to drum top	0.005	0.003	0.000	0.004	13:38	20
C	Motor housing area	0.000	0.000	0.008	0.004	13:40	40
D	HEPA filter air hose exit point from drum top lid	0.000	0.006	0.003	0.005	13:42	55
E	HEPA filter air hose entry point to HEPA filter housing	0.003	0.000	0.006	0.005	13:43	75
F	HEPA filter hose exit point from filter to carbon filter	0.027	0.235	-	0.131	13:44	93
F	HEPA filter hose exit point from filter to carbon filter	0.003	0.005	0.152	0.079	13:45	110
G	HEPA air hose connection entry to carbon filter	0.008	0.000	0.005	0.007	13:47	133
H	Carbon filter housing lid rim area	0.003	0.005	0.003	0.004	13:48	147
I	Fan exit air stream	0.003	0.003	0.003	0.003	13:49	162
J	Drum lid rim area near HEPA filter	0.008	0.000	0.003	0.006	13:50	190
K	Drum lid rim area near Carbon filter	0.010	0.003	0.009	0.010	13:51	207
M	Drum lid rim area opposite HEPA filter	0.000	0.000	0.000	0.000	13:52	228
N	Drum lid rim area opposite carbon	0.000	0.005	0.000	0.003	13:53	245
OBZ	Operator Breathing Zone (OBZ)	0.000	0.000	0.000	0.000	13:55	258
O ₃	Other – Between HEPA filter housing and drum wall on entry side to HEPA filter housing	0.193	0.428	0.183	0.311	14:02	375
O ₄	Other – Between HEPA filter housing and drum wall on exit side of HEPA filter housing	0.403	0.743	0.013	0.573	14:04	402
O ₅	Other – Under HEPA filter housing 2 inches from drum wall and 2 inches from HEPA filter housing	0.003	0.003	0.003	0.003	14:05	436
O ₆	Other – Electric control panel housing	0.007	0.004	0.007	0.007	14:07	456
OBZ	Operator Breathing Zone	0.000	0.000	0.000	0.000	14:08	489
I	Fan exit air stream; 6-8 inches below carbon filter housing	0.006	0.007	0.004	0.007	14:10	505
K	Drum lid rim area near Carbon filter	0.006	0.004	0.003	0.005	14:14	577
Note	<i>Thermal Blower cut-out activated and shut-down due to overheating; restart after 3 minutes</i>	-	-	-	-	-	578
O ₇	Other – Between carbon filter housing and drum wall on entry side to carbon filter housing	0.000	0.003	0.000	0.002	14:22	600
O ₈	Other – Between carbon filter housing and drum wall on exit side of carbon filter housing	0.000	0.003	0.000	0.002	14:24	620
L	Lamp chute entry connection to drum top	0.000	0.000	0.000	0.000	14:25	635
M	Drum lid rim area opposite HEPA filter	0.000	0.000	0.000	0.000	14:26	650
OBZ	Operator Breathing Zone	0.000	0.000	0.000	0.000	14:28	684
O ₃	Other – Between HEPA filter housing and drum wall on entry side to HEPA filter housing	0.000	0.009	0.042	0.026	14:30	706
O ₄	Other – Between HEPA filter housing and drum wall on exit side to HEPA filter housing	0.141	0.033	0.027	0.087	14:35	745
A ₃	Ambient Hg conc. motor off, 4-6" above floor	0.000	0.000	0.000	0.000	14:50	750
O ₁₁	Other – within 2 inches of drum-drum lid interface at three points around full waste drum top	0.004	0.007	0.005	0.006	14:55	750

Table 10. Bulb Eater™ Model 55 VRS (Navy Prototype) DRI Measurements Summary
Second Test Cycle
24 October 2002

Sample Point	Description	1 st Reading (mg/m3)	2 nd Reading (mg.m3)	3 rd Reading (mg.m3)	Avg. Value mg/m3	Time Hr:Min	Lamp Count
A ₁	Ambient Hg conc. before motor on, 4-6" above floor	0.000	0.000	0.000	0.000	16:46	0
O ₁	Other – Bag filter change out; 3-4 inches from fist stage filter opening with filter housing removed	0.040	0.029	0.019	0.035	16:48	0
O ₂	Other – Bag filter change out; OBZ during bag filter removal	0.009	0.005	0.000	0.007	16:50	0
O ₃	Other – Bag filter change out; OBZ during first stage filter installation with filter housing removed	0.003	0.011	0.010	0.011	16:52	0
O ₄	Other – OBZ during new first stage filter installation	0.003	0.011	0.10	0.011	16:52	0
A ₂	Ambient Hg conc. after motor on, 4-6" above floor	0.003	0.000	0.000	0.002	17:18	0
B	Lamp chute entry point	0.000	0.000	0.000	0.000	17:19	10
E	HEPA filter air hose entry point to HEPA filter housing	0.011	0.000	0.000	0.006	17:27	50
C	Motor housing area	0.005	0.003	0.003	0.004	17:28	85
D	HEPA filter air hose exit point from drum top lid	0.007	0.006	0.000	0.007	17:30	105
F	HEPA filter hose exit point from filter to carbon filter	0.005	0.003	0.000	0.004	17:31	121
G	HEPA air hose connection entry to carbon filter	0.023	0.016	0.006	0.020	17:32	133
O ₅	Other - Between HEPA filter housing area and drum wall on exit side of HEPA filter	0.097	0.834	0.318	0.576	17:33	160
O ₆	Other – Between HEPA filter housing area and drum wall on entry side to HEPA filter	0.009	0.013	0.014	0.014	17:36	190
O ₇	Other – 1" below HEPA filter housing between filter housing and drum wall	0.004	0.000	0.000	0.002	17:37	210
OBZ	Operator Breathing Zone (OBZ)	0.000	0.000	0.000	0.000	17:38	224
K	Drum lid rim area near Carbon filter	0.012	0.007	0.009	0.011	17:39	240
I	Fan exit air stream	0.000	0.000	0.006	0.003	17:40	255
I	Fan exit air stream	0.000	0.000	0.006	0.003	17:42	274
H	Carbon filter housing lid rim area	0.003	0.000	0.000	0.002	17:44	320
L	Lamp chute entry connection to drum top	0.003	0.000	0.003	0.003	17:45	332
M	Drum lid rim area opposite HEPA filter	0.004	0.005	0.009	0.007	17:46	350
N	Drum lid rim area opposite carbon	0.003	0.004	0.005	0.005	17:47	369
O ₈	Other – Control panel housing	0.003	0.004	0.004	0.004	17:48	384
OBZ	Operator Breathing Zone (OBZ)	0.000	0.000	0.000	0.000	17:49	401
O ₄	Other - Between HEPA filter housing area and drum wall on exit side of HEPA filter	0.246	0.089	0.414	0.330	17:50	415
O ₃	Other – Between HEPA filter housing area and drum wall on entry side to HEPA filter	0.007	0.005	0.025	0.016	17:52	440
O ₈	Other – Top seams of HEPA filter housing	0.003	0.008	0.008	0.008	17:53	457
OBZ	Operator Breathing Zone (OBZ)	0.000	0.000	0.000	0.000	17:54	472
B	Lamp chute entry point	0.003	0.000	0.003	0.003	17:56	485
C	Motor housing area	0.003	0.004	0.004	0.004	18:00	535
D	HEPA filter air hose exit point from drum top lid	0.000	0.004	0.003	0.004	18:02	558
E	HEPA filter air hose entry point to HEPA filter housing	0.005	0.003	0.003	0.004	18:03	568
Note	<i>Thermal Blower cut-out activated and shut-down due to overheating; restart after 2 minutes 10 seconds</i>	-	-	-	-	-	577
F	HEPA filter hose exit point from filter to carbon filter	0.015	0.005	0.004	0.010	18:10	592
G	HEPA air hose connection entry to carbon filter	0.003	0.006	0.014	0.010	18:11	614
H	Carbon filter housing lid rim area	0.000	0.000	0.005	0.003	18:12	630
O ₆	Other – Between HEPA filter housing area and drum wall on entry side to HEPA filter	0.008	0.022	0.004	0.015	18:14	660
I	Fan exit air stream	0.000	0.000	0.000	0.000	18:15	675

**Table 10. Bulb Eater™ Model 55 VRS (Navy Prototype) DRI Measurements Summary
Second Test Cycle
24 October 2002**

Sample Point	Description	1 st Reading (mg/m3)	2 nd Reading (mg.m3)	3 rd Reading (mg.m3)	Avg. Value mg/m3	Time Hr:Min	Lamp Count
J	Drum lid rim area near HEPA filter	0.006	0.003	0.013	0.010	18:17	680
OBZ	Operator Breathing Zone (OBZ)	0.000	0.000	0.000	0.000	18:19	702
Note	<i>Thermal Blower cut-out activated and shut-down due to overheating; restart after 3 minutes</i>	-	-	-	-	-	702
I	Fan exit air stream-six inches above floor and directly beneath carbon housing	0.000	0.000	0.000	0.000	18:27	710
K	Drum lid rim area near Carbon filter	0.007	0.000	0.000	0.004	18:28	720
OBZ	Operator Breathing Zone (OBZ)	0.000	0.000	0.000	0.000	18:29	725

A summary of the Jerome Mercury Vapor Analyzer DRI sample results (i.e. real time 10-second integrated DRI readings) during operations of the Bulb Eater™ Model 55VRS (Navy Prototype) is presented in Figure 3. The sample point letter-designators and mercury vapor measurements highlighted in yellow reveal locations on the where mercury vapor concentrations exceeded the ACGIH TLV-TWA equal to 0.025 mg/m³. The sample measurements highlighted in the color green reveal locations on the Bulb Eater™ where mercury vapor concentrations equaled or exceeded the OSHA PEL-TWA equal to 0.100 mg/m³. DRI measurements were made within

Figure 3. Sample Locations Depicting Mercury Emissions' Areas in Excess of OSHA PEL and ACGIH TLV

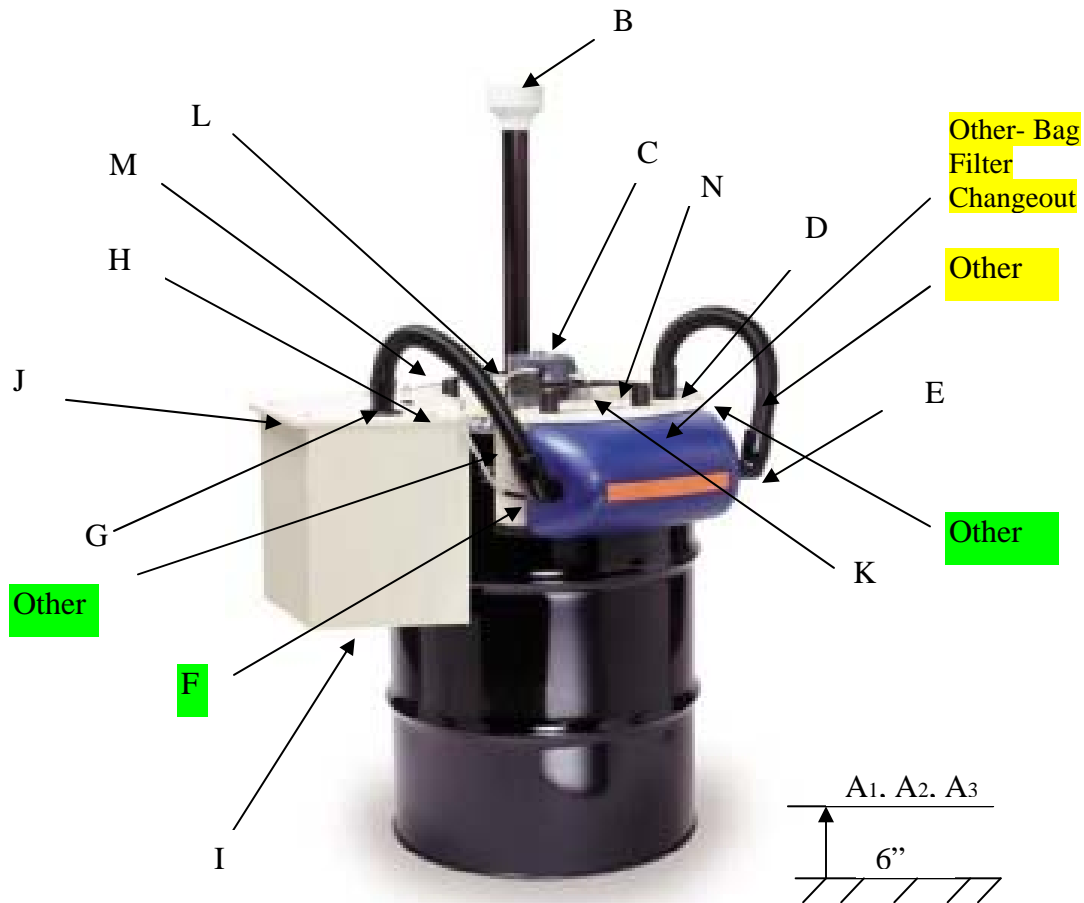

two to three inches of the unit at each of the sample points and within six inches directly beneath the air exhaust area of the Bulb Eater's emission control device.

As can be gleaned from the above tables and diagram mercury vapor concentrations exceeding the ACGIH TLV-TWA and the OSHA PEL of 0.100 mg/m³ (as real time 10-second integrated DRI readings) for mercury are associated with the HEPA filter housing area connections and seams. Additionally the mercury vapor concentrations (as real time 10-second integrated DRI readings) exceeded the ACGIH TLV-TWA for mercury in the operators breathing zone during filter bag change-out.

The Bulb Eater™ Slant Model 55VRS DRI Measurement Summary during Drum Change-out

During the Bulb Eater™ drum change-out operation, DRI measurements were collected in the breathing zone of the operator. A helper assisted the operator during the drum change-out operations. Table 12 contains a summary of the DRI mercury vapor measurement results recorded during the drum change-out operation. The table data highlighted in the colors green and yellow reveals that mercury vapor concentrations increase rapidly above established ACGIH TLV-TWA and OSHA PEL-TWA (as real time 10-second integrated DRI readings) within seconds after the Bulb Eater™ lid removal from the crushed lamp collection drum and prior to placing a drum lid atop the full drum.

Excessive mercury vapor concentrations (as real time 10-second integrated DRI readings) were immediately detected with the mercury vapor concentrations rising to and exceeding 0.224 mg/m³. After lid placement on the waste drum and unit placement on the empty waste drum the mercury vapor concentrations diminished to 0.019 mg/m³ and 0.006 mg/m³ respectively for the test cycles.

During removal and replacement of the used bag filter after the first test cycle the mercury vapor concentrations reached 0.035 mg/m³ during the 1-2 minutes required for this operation.

Table 12. The Bulb Eater™ Model 55VRS (Navy Prototype) Drum Change-out DRI Measurements Summary (24 October 2002)							
Sample Point	Description	1 st Reading (mg/m3)	2 nd Reading (mg.m3)	3 rd Reading (mg.m3)	Avg. Value mg/m3	Time Hr:Min	Lamp Count
End of First Test Cycle							
O ₁₂	Other – OBZ; drum change-out – unit off waste drum	0.000	0.322	0.166	0.244	14:57	750
O ₁₃	Other – OBZ; drum change-out – lid placed on drum	0.078	0.016	0.019	0.049	14:58	750
O ₁₄	Other –OBZ; drum change-out unit placed/attached to empty waste drum	0.008	0.007	0.029	0.019	15:00	750
End of Second Test Cycle							
O ₉	Other – OBZ; drum change-out – unit off waste drum; attach lid to waste drum	0.401	0.058	0.004	0.230	18:33	750
O ₁₀	Other – OBZ; drum change-out – lid placed on drum	0.006	-	-	0.006	18:33	750

Qualitative Sampling for Presence of Mercury Surface Contamination

A mercury surface sampling kit was used to qualitatively detect the presence of mercury on the surfaces of the waste drums at the completion of the each test cycle. Mercury contamination was qualitatively detected on the outside surfaces of the two full waste drums as indicated by changes in the color strip from the test kit. As a result, the drums were wiped down and the wipes disposed as hazardous waste along with other mercury contaminated expendables.

Sound Pressure Levels Associated with Bulb Eater™ Operations

Sound pressure (noise) levels in decibels, A-scale (dBA), slow response, were measured with a calibrated Quest Sound Level Meter (SLM) Model 2100 during crushing operations. All test personnel were required to wear protective earplugs. Table 22 contains the results of the SLM noise measurements.

Table 22. Bulb Eater™ Sound Pressure Levels	
Location	Noise Level Range (dBA)
Air Cycle Corporation Warehouse Bay Test Area (Background prior to tests)	61-66
Bulb Eater™ Model 55VRS (Navy Prototype)	86-88 *

* Hearing protection required above 85 dBA (slow response) per OSHA noise regulations and 84 dbA (slow response) per Navy Occupational Safety and Health regulations

As a result of the Bulb Eater™ Model 55VRS (Navy Prototype) SLM exceeding 84 dBA during lamp crushing operations, hearing protection is required during operation.

Discussion of Test Results

Personal and Area Air Sampling

The Bulb Eater™ operator, the East, West, and South perimeter areas, and the Bulb Eater™ emission control device exhaust air streams did not exceed the ACGIH TLV-TWA 0.025 mg/ m³ or the OSHA PEL-TWA 0.100 mg/ m³ exposure limits for mercury during the actual time that each test cycle was conducted nor over the 8-hour work day that the two test cycles were performed during the crushing of 1500 fluorescent lamps. The mercury vapor airborne concentration measured in the breathing zone of the Bulb Eater™ operator, in all perimeter area samples, and at the unit's emissions' control device's were "None Detected" or less than 0.00005 mg, the analytical detection limit, while crushing 750 lamps each during two test cycles on 24 October 2002. The operator's personal breathing zone, perimeter area samples', and the unit's emissions' control device's 8-hour TWAs for mercury vapor was "None Detected" or less than the analytical detection limit of 0.00005 mg on the test day.

Based on air contaminant sampling results, the operator and surrounding areas are not exposed to excessive concentrations of mercury vapor during either of the Bulb Eater™ fluorescent lamp crushing operations. Additionally, the Bulb Eater™ emission control device

exhaust air streams were not laden with mercury vapor airborne concentrations exceeding OSHA or ACGIH mercury exposure limits.

Drum change-out and filter replacement operations revealed the Bulb Eater™ has potential to exceed both ACGIH TLV-TWA and OSHA PEL-TWA mercury vapor exposure limits. These operations include the Bulb Eater™ unit removal from the full crushed lamp collection drum, full crushed lamp collection drum lid removal, and full crushed lamp collection drum lid replacement and tightening, and during filter unit change-out and replacement. Additionally, the full waste drums are likely to be contaminated with mercury particulate at the end of crushing operations.

Test Personnel and PPE Contamination

Mercury contamination was not detected on test personnel's PPE and clothing using the Jerome 431 DRI at the tests conclusion.

Noise Measurements

The Bulb Eater™ Model 55VRS sound pressure (noise) levels in dBA, slow response, measured with a calibrated Quest SLM during crushing operations ranged from 86 to 88 dBA. Hearing protection (e.g., ear plugs) is required during the Bulb Eater™ crushing operations.

Conclusions

The following conclusions are made based on the Bulb Eater™ Model 55VRS (Navy Prototype) test data and evaluation:

1. The Bulb Eater™ system efficiently crushed fluorescent lamps. The Bulb Eater™ system can crush 750 lamps with an average 4-foot length well within 90 minutes into one 55-gallon drum period if the used lamps are properly staged and a helper is used to assist in lamp handling.
2. Operator exposure to excessive mercury concentrations in air did not exceed OSHA or ACGIH exposure limits during the actual crushing operation or when averaged over an 8-hour work period.
3. End caps designed to seal open ends of lamp chutes adequately contain contaminated lamp chutes during storage and non-use.
4. Attached plugs for use with HEPA filter housing hoses adequately contain contaminated HEPA housing hoses during storage.
5. Contamination from the crushing mechanism side of the Bulb Eater™ system emits mercury vapor when the unit is separated from the 55-gallon crushed lamp collection drum. Placement and attachment to the 10-gallon storage drum remedies mercury contamination issues in storage areas.

References

1. Air Cycle Corporation Bulb Eater™ Model 55 VRS Premium Owner'
2. American Conference of Governmental Industrial Hygienists. (2001). Threshold Limit Values and Biological Exposure Indices for 2001. Cincinnati: Author.
3. GE Lighting. Lamp literature. [Online]. Available: <http://www.gelighting.com> [December 2001].
4. National Academy of Sciences. (1996). Spacecraft Maximum Allowable Concentrations for Selected Airborne Contaminants: Volume 2. [Online]. Available: <http://books.nap.edu/books/0309054788/html/251.html> [January 2002].
5. SKC Inc. Product information. [Online]. Available: <http://www.skcinc.com> [January 2002].
6. U.S. Occupational Safety and Health Administration (OSHA) Code of Federal Regulations (CFR) Title 29 Section 1910.1000, Air Contaminants, Table Z-2
7. U.S. OSHA. Compliance directive defining mercury TWA versus Ceiling Limits. Available: www.osha.gov/pls/oshaweb/owadisp.show_document?p_table=INTERPRETATION [January 2002].
8. National Institute of Occupational Safety and Health. (1994). National Institute of Occupational Safety and Health (NIOSH) Analytical Methods, Fourth Edition. Washington, DC: Author.

Appendix A

Test Equipment Information and Calibration Data

Table A-1 presents a complete list of equipment assembled and used during the Bulb Eater™ Model 55VRS (Navy Prototype) laboratory tests.

Table A-1. Bulb Eater™ Test Equipment		
Item	Description	QTY
Bulb Eater™ Units and Accessories		
BulbEater™	Air Cycle Corporation BulbEater™ Model 55VRS (Navy Prototype) and accessories	1
Drum Dolly	Air Cycle Corporation BulbEater™ 55-gallon Drum Dolly (Air Cycle Part Number 55-470)	1
55- gal. Drum	Crushed Lamp Waste Drums	2
Sampling, Measurement, Spill Equipment		
Mercury Vapor Analyzer	Arizona Instruments Corp. Jerome 431 Direct Reading Mercury Vapor Analyzer	1
Sound Level Meter	Quest Sound Level Meter, Type II, Model 215, Serial Number M1010023	1
Air Sampling Pumps	SKC 222 Low Flow Sampling Pumps with Accessories	5
Calibration System	SKC DryCal DC-Lite Flowmeter (2-500 ml/min) for use in Air Sampling Pump Calibration	1
Mercury Sampling Media	SKC Anasorb CSC Coconut Charcoal, 200/80mg, pack of 50 (Catalog Number 226-17-1A)	1
Sampler Holder	SKC Mercury Sampler Reusable Capsule Holder	4
Tube Holder	SKC Tube Holder (for 6 mm OD x 70 mm)	5
Mercury Surface Sampling Kit	SKC Mercury Surface Sampling Kit (Mercury Check Swabs) (pack of 8) (Lab Safety Catalog Number 1A-25885)	1
Sound Level Meter Calibrator	Quest Sound Calibrator Model CA-123, Serial Number 01010123	1
Smoke Tube Kit	MSA Air Current Test Kit containing one aspirator bulb and 10 smoke tubes	1
Personal Protective Equipment		
Chemical Impact Goggles	American LLSafe Co. Chemical Splash and Impact Goggles, Respirator Fit Style, Indirect Vent (Lab Safety Catalog Number 1A-11356)	4
Neoprene-Coated Gloves	Neoprene-Coated Gloves, Chemical, Abrasion, Puncture and Tear Resistant (pair) (Lab Safety Catalog Number 1A-17511)	12
Disposable Coveralls	Tyvek® Disposable Coverall with zip-up front, open wrists, with boot covers (6 extra large)	6
Hearing Protectors	Various manufacturer name-brand earplugs	6
PPE Storage Bags	Polyethylene Storage Bags, Sealable	4
Miscellaneous Equipment		
Tools	Wrenches and screw drives as required for set up.	-
Markers	Paint pens	1

Table A-1. Bulb Eater™ Test Equipment		
Item	Description	QTY
Bulb Eater™ Units and Accessories		
BulbEater™	Air Cycle Corporation BulbEater™ Model 55VRS (Navy Prototype) and accessories	1
Drum Dolly	Air Cycle Corporation BulbEater™ 55-gallon Drum Dolly (Air Cycle Part Number 55-470)	1
55- gal. Drum	Crushed Lamp Waste Drums	2
Duct Tape	11-mil, industrial grade cloth & polyethylene film	1
Plastic Sheeting Floor Tarp	Polyethylene sheeting, 5 mil thickness (10 ft x 10 ft.) for use on floor under test unit	1

Direct Reading Instrument Calibration

Jerome Gold Film Mercury Vapor Analyzer Model 431

Description: The Jerome 431 portable instruments will operate five hours on fully charged batteries. The 10-second sample mode provides an integrated, direct reading of mercury vapor concentration in mg/m³. The 1-second SURVEY mode allows quick checks to locate high concentration areas. The microprocessor automatically zeroes the digital meter at the start of each sample cycle and freezes the meter reading until the next sample cycle is activated, thus eliminating drift between samples.

Principle Of Operation: A thin gold film, in the presence of mercury vapor, will undergo an increase in electrical resistance proportional to the mass of mercury in the sample. Activating either the 10-second sample or 1-second survey mode starts an internal pump that draws a precise volume of air over the Gold Film Sensor. The Gold Film Sensor adsorbs and integrates the mercury vapor, and the resulting signal is displayed on the digital meter. As mercury adsorbs on the sensor, the percentage of saturation is indicated on the digital meter by pressing the sensor status button. Approximately forty 10-second samples containing 0.1 mg/m³. Mercury may be taken before the sensor reaches saturation. At this point, a 15-minute heat cycle is manually activated to desorb the accumulated mercury from the sensor. An internal charcoal filter prevents contamination from the desorbed mercury.

Calibration: The Jerome 431 was factory-calibrated within one year of the test date.

Operational Tests Conducted Prior to Use: Before each day's use of the factory-calibrated Jerome 431, four manufacturer recommended steps were performed to verify each unit was operational – power on – battery check; film heat procedure for cleaning mercury from unit; and, sample in clean air for reading of 0.000 mg/m³ mercury.

Quest 2100 Sound Level Meter, SN 0020006

The Quest 215 Sound Level Meter was factory calibrated to ANSI S1.4 on 12-17-01 and was due for factory calibration on 12-17-02. The Quest 2100 Sound Level Meter was calibrated prior to each use on site using a Quest Sound Calibrator Model CA-128,

SN 01010123, 114 dBA, slow response, 1000-hertz source. The calibrated readings obtained ranged from 113.5 to 114 dBA, slow response with the 114-dBA, 1000-hertz calibration source and were within (+) or (-) 1.0 dBA specified by the manufacturer for successful field calibration.

Personal and Area Air Sampling Pump Calibration

SKC, Inc. Model 222-3 low flow air sampling pumps attached to SKC Inc. Anasorb CSC[®] charcoal tubes by Tygon[®] tubing and protected in SKC charcoal tube holders were used by the Project Industrial Hygienist (IH) to collect operator and the operator’s helper breathing zone TWA air samples and area TWA air samples around the units during each test cycle. The SKC low flow air pumps were calibrated between 180-210 milliliters per minute (ml/min) using a SKC DryCal DC-Lite Flowmeter (range 2-500 ml/min). Calibration data acquired for each sampling pump is provided in the Table E-2.

Table E-2. SKC Model 222-3 Personal Air Samplers’ Pump Calibration			
Date	Pump Number	Pump Serial Number	Flow Rate (ml/min.)
11Mar02 (AM)	1	2-029-12	184.5
	2	9-200-02	194.7
	3	9-200-09	170.9
	4	9-200-03	181.06
	5	9-200-07	181.9
	6	2-029-13	191.1
	7	01-051-07	180.2
12Mar02 (AM)	1	2-029-12	184.7
	2	9-200-02	193.9
	3	9-200-09	170.1
	4	9-200-03	181.5
	5	9-200-07	184.5
	6	2-029-13	181.3
	7	01-051-07	178.8
12Mar02 (PM)	1	2-029-12	184.7
	2	9-200-02	193.9
	3	9-200-09	170.1
	4	9-200-03	181.5
	5	9-200-07	184.5
	6	2-029-13	181.3
	7	01-051-07	178.8
12Mar02 (PM)	1	2-029-12	184.8
	2	9-200-02	190.3
	3	9-200-09	172.3
	4	9-200-03	180.5
	5	9-200-07	185.8
	6	2-029-13	182.4
	7	01-051-07	173.4

Table E-2. SKC Model 222-3 Personal Air Samplers' Pump Calibration			
Date	Pump Number	Pump Serial Number	Flow Rate (ml/min.)
13Mar02 (AM)	1	2-029-12	188.3
	2	9-200-02	198.5
	3	9-200-09	173.4
	4	9-200-03	180.4
	5	9-200-07	186.3
	6	2-029-13	184.8
	7	01-051-07	180.7
23Oct02 (Pre-calibration)	1	2-029-12	187.6
	2	9-200-02	182.0
	1	09-200-01	194.9
	2	09-200-06	203.8
	3	09-200-08	199.3
	4	09-200-09	206.1
	5	09-200-10	205.5
24Oct02 (Post-calibration)	1	09-200-01	186.3
	2	09-200-06	197.2
	3	09-200-08	194.9
	4	09-200-09	208.9
	5	09-200-10	198.7

Appendix B

Laboratory Sample Analytical Results and Chain of Custody Forms

(Note: Included in hard copy report)

Appendix C

Abbreviations and Glossary

Abbreviations

ACGIH	American Conference of Governmental Industrial Hygienists
AVG	Average
C	OSHA Ceiling limit value
CIH	Industrial Hygienist
EPA	U.S. Environmental Protection Agency
ft	Foot or Feet
gal	Gallon
HEPA	High Efficiency Particulate Aerosol
Hg	Mercury
Hz	Hertz
ID	Identity
in	Inch
L	Liter or Length
lbs	Pounds
mfr	Manufacturer
mg	Milligram
mg/m ³	Milligrams Per Cubic Meter
mm	Millimeter
MSHA	Mine Safety and Health Administration
NAS	National Academy of Sciences
NIOSH	National Institute of Occupational Safety and Health
OD	Outside Diameter
OSHA	U.S. Occupational Safety and Health Administration
PEL	Permissible Exposure Limit
PPB	Parts Per Billion
PPE	Personal protective equipment
QTY	Quantity
REEL	Recommended Environmental Exposure Limit
REQ	Requirement
SKC	SKC, Inc.
SMAC	Spacecraft Maximum Allowable Concentration
T-10	Lamp tube diameter 5/6 inch
T-12	Lamp tube diameter 1 inch
TLV	ACGIH Threshold Limit Value
TWA	Time-weighted average

Glossary

Ceiling Value. OSHA air contaminant airborne concentration that should not be exceeded during any part of the working exposure.

Excursion Limit. ACGIH recommended limit – “Excursions in worker exposure levels may exceed 3 times the TLV-TWA for no more than a total of 30 minutes during a workday, and under no circumstances should they exceed 5 times the TLV-TWA, provided the TLV-TWA is not exceeded”.

Fluorescent Lamp. Discharge lamp of the low-pressure mercury type in which most of the light is emitted by a layer of fluorescent material excited by the ultraviolet radiation from the discharge. This term is most commonly applied to low-pressure tubular fluorescent lamps.

Fluorescent Lamp Crushing Device (FCLD). A mechanical waste treatment device usually placed atop a 55-gallon drum used to safely crush fluorescent lamps of various lengths and diameters, filter and trap elemental mercury and mercury vapor and reduce the volume of waste generation.

Permissible Exposure Limit (PEL). The allowable 8-hour time-weighted average regulatory exposure limit for an air contaminant established by OSHA to which nearly all workers may be repeatedly exposed on a daily basis without adverse health effects.

Short Term Exposure Limit (STEL). The 15-minute time-weighted average exposure limit set by the American Conference of Governmental Industrial Hygienists (ACGIH), which will not be exceeded during a workday even if the measured 8-hour TWA is within the TLV-TWA.

Threshold Limit Value (TLV). Refers to airborne concentrations of substances and represent conditions under which it is believed that nearly all workers may be repeatedly exposed day after day without adverse health effects. TLVs, as issued by ACGIH, are recommendations and should be used as guidelines for good practices.

Time-weighted average (TWA). The average airborne exposure in an 8-hour work shift of a 40-hour workweek established by OSHA that will not be exceeded.

U.S. Occupational Safety and Health Administration (OSHA). An agency of the U.S. Department of Labor, which is the regulatory and enforcement agency for occupational safety and health in most U.S. industrial sectors. This Federal agency lists over 500 substances as air contaminants and establishes the limits of exposure by inhalation to these substances.